



Electric scissor lift
JCPT1212HD

Electric scissor lift JCPT1212HD









STANDARD EQUIPMENT

- Proportional controls
- Automatic pothole protection
- Self-lock gate on platform
- Drivable at full height
- Non marking tires
- 2WD
- Automatic brakes system
- Emergency lowering system
- Emergency stop button
- Cylinder holding valve
- Onboard diagnostic system
- Tilt sensor with alarm
- All motion alarm
- Horn
- Hour meter
- Safety brackets
- Forklift pockets
- Folding guardrails
- Extended platform
- Charger protection
- Flashing beacon

OPTIONS

- Overload sensor with alarm
- AC power to the platform
- Platform work lights
- Airline to the platform

SPECIFICATIONS

	Platform capacity (SWL).....	320 kg
	Platform capacity (SWL) on extension.....	113 kg
	Maximum workers number.....	2
	Working height.....	12,0 m
	Platform floor height.....	10,0 m
	Overall length.....	2,48 m
	Overall width.....	1,15 m
	Overall height (Rails up).....	2,47 m
	Overall height (Rails down).....	1,99 m
	Platform size.....	2,27 x 1,12 m
	Platform extension size.....	0,9 m
	Ground clearance (Stowed).....	0,10 m
	Ground clearance (Raised).....	0,019 m
	Wheelbase.....	1,87 m
	Turning radius (inside).....	0 m
	Turning radius (outside).....	2,20 m
	Lifting motor.....	24 V / 3 kw
	Travel speed (Stowed).....	3,5 km / h
	Travel speed (Raised).....	0,8 km / h
	Up / Down speed.....	45 / 36 sec
	Batteries.....	4 x 6 V / 210 Ah
	Integrated charger.....	24 V / 25 A
	Gradeability.....	25 %
	Maximum working slope.....	2 - 3 °
	Tires.....	Ø 381 x 127 mm
	Weight.....	2430 kg

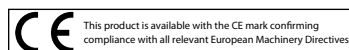
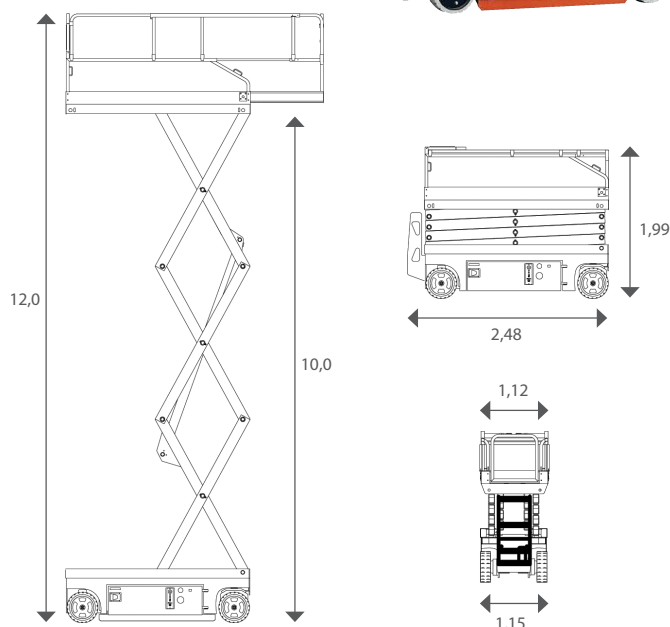

www.dingli.eu

INSTANT

Norway
Tel.: +47 23 19 11 00
info@instant.no

Lithuania
Tel.: +370 5 233 1096
info@instant.lt

Latvia
Tel.: + 371 263 58 152
info@instantlatvija.lv

Estonia
Tel.: +372 680 76 33
info@instanteesti.ee