

# Specifications

# LEO 23GT

MEASUREMENTS	Metric	US
Working height, max.	23,00 m	74 ft 10 in
Horizontal outreach with 200 kg	11,20 m	36 ft 8 in
Up-and-over clearance, max.	11,50 m	37 ft 9 in
Platform height (A)	1,10 m	3 ft 7 in
Platform length (B)	1,42 m	4 ft 8 in
Platform width (C)	0,70 m	2 ft 3 in
Length, overall (D)	6,20 m	20 ft 4 in
Length without basket (E)	-	-
Height, travelling position (F)	1,97 m	6 ft 6 in
Width, min. (G)	0,98 m	3 ft 3 in
Ground clearance, max. (H)	0,40 m	1 ft 3 in
Track (L x W) (I)	1,45 m x 0,20 m	4 ft 9 in x 7¾ in
Length outrigger footprint standard (J)	4,53 m	14 ft 10 in
Width outrigger footprint standard (K)	4,33 m	14 ft 3 in
Length footprint one side narrow (L)	5,98 m	19 ft 7 in
Width footprint one side narrow (M)	3,42 m	11 ft 3 in
Width footprint both sides narrow (N)	2,58 m	8 ft 6 in
Outrigger plate Ø	0,18 m	7 in

PRODUCTIVITY	Metric	US
Basket capacity	200 kg	441 lbs
Movable Jib	-	-
Basket rotation	180°	180°
Turret rotation	360°	360°
To be jacked up on ground slope of	16,7°/30,0 %	16.7°/30.0 %
Height and width track adjustment	23/45 cm	9/17¼ in
Gradeability, max.	16,7°/30,0 %	16.7°/30.0 %
Slope angle	15,5°/27,0 %	15.5°/27.0 %
Travel speed	1,3 km/h	0.8 mph

WEIGHT	Metric	US
Total weight	2990 kg	6592 lbs
Live load in travelling position	4,02 kN/m <sup>2</sup>	84.0 psf
Live load in working position	1,78 kN/m <sup>2</sup>	37.2 psf
Point load per outrigger plate, max.	22,4 kN	5036 lbf

POWER	
Standard power sources (Electric and combustion engine)	1) <b>Electric:</b> EU: 230 V, 12,9 A, 2,2 kW US: 115 V, 19.3 A, 1,6 kW 2) <b>Diesel:</b> Kubota Z 602 (10,8 kW/14,5 hp)
Optional power sources	<b>Li-Ion Battery:</b> 48 V
Fuel tank capacity Diesel engine	12,0 l 3.17 gal

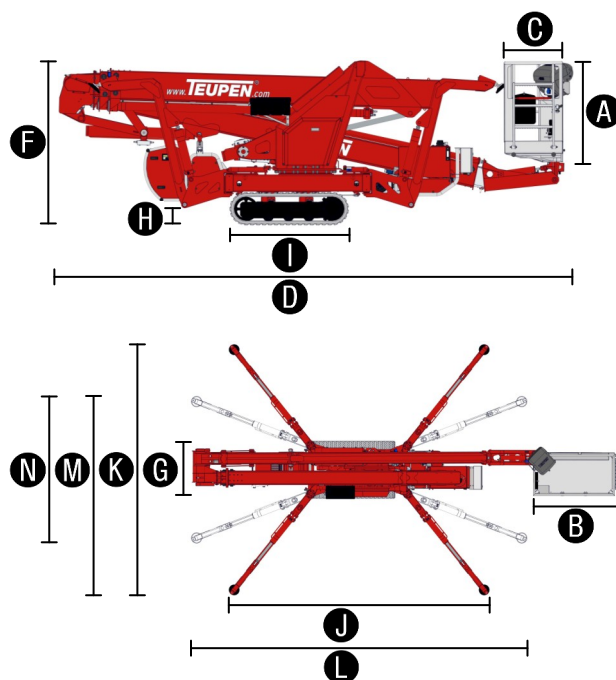

## WORKING ENVELOPE

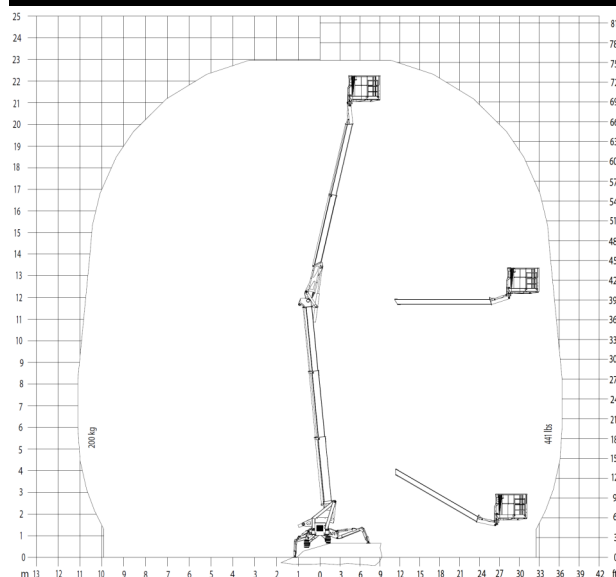

## STANDARDS COMPLIANCE



EN ISO 9001



ANSI A92.5-2006  
CSA B354.1-04  
EN 280:2001

Product specifications are subject to change without notice or obligation. Photographs and drawings in this document are for illustrative purposes only. Refer to the appropriate Operator's Manual for instructions on the proper use of this equipment. Failure to follow the appropriate Operator's Manual when using our equipment or to otherwise act irresponsibly may result in serious injury or death. The only warranty applicable to our equipment is the standard written warranty applicable to the particular product and sale and we make no other warranty, expressed or implied. Products and services listed may be trademarks, service marks or trade-names of Teupen Maschinenbau GmbH and/or its subsidiaries in the U.S.A. and many other countries. "Teupen", "Access redefined" and "LEO Series" are registered Trademarks of Teupen GmbH in the United States of America and many other countries. Version 2015-A © 2015 Teupen Maschinenbau GmbH.

# Features

## TRACK CHASSIS

- Powerful track drive with hydraulic braking system
- Precise maneuvering over sensitive electrohydraulic cable remote control
- Rubber tracks with specially arranged profile providing optimum grip
- White, non-marking rubber tracks
- Height- and width adjustable track chassis

## STABILISATION

- Fully-hydraulic, automatic levelling system with outrigger/stabiliser setup monitoring
- Variable stabiliser/outrigger system with one-side or both-sides narrow setup option
- Wear resistant, anti-friction PVC outrigger/stabiliser feet

## BOOM SYSTEM

- Telescoping upper- and lower booms, trapezium-shaped with Teflon sliding blocks
- All functions are available from one control panel
- Electric-proportional controls with intuitive operator guidance
- Robust, lockable control panel with integrated operation function
- Self-levelling platform with fully-hydraulic levelling system
- Corner-mounted, 180° turnable basket for extra flexibility
- Boom rotation via high-performance slew ring, worm gear and hydraulic motor
- Resting support system prevents incorrect positioning of boom in transport bracket

## POWER SOURCES

- 230 V electric motor (EU), 115 V electric motor (US)
- Kubota diesel engine Z602 with electronically regulated engine control
- Start-Stop switch of combustion engine in the basket

## PRODUCTIVITY, SAFETY, QUALITY

- 230 V (EU), 115 V (US) power outlet in the basket
- Ergonomically shaped basket with eyelets for safety belts and tool tray
- Lockable storage box for cable remote control
- High-quality paint in RAL 3020 (red)
- Hydraulic emergency lowering over hand pump
- Cables and hoses are safely routed through the boom structure
- Biodegradable hydraulic oil
- Lock valves - hydraulic return valves directly on all hydraulic cylinders
- Relief valves protecting the hydraulic system from too high pressures
- Protective covers for oil-tank, emergency controls and connecting cables and hoses
- Protective covers for electric housing, ground control panel and telescopic cylinder
- Easily removable covers for optimal accessibility
- Hour meter
- Complete second control box on the chassis and error analysis with display
- Fuzzy IV control technology



## OPTIONS

- Li-Ion Battery drive 48 V\*\* instead of Diesel engine  
This option can not be combined with the electric emergency lowering
- Custom paintwork, one colour, according to RAL scheme (except metallic coatings, signal- or special colors)
- Custom paintwork, two colours, according to RAL scheme (except metallic coatings, signal- or special colors)
- Hydraulically height- and width-adjustable track chassis instead of the mechanically height- and width-adjustable track chassis
- Electric emergency lowering (12 kg/24 lbs additional weight)  
This option can not be combined with the battery drive

\*\* When using the Low trailer is this option not possible to keep total weight below the permissible gross laden weight of 3,5t.

## ACCESSORIES

- Outrigger/Stabiliser pad (450 x 400 x 40 mm/1 ft 5 in x 1 ft 4 in x 1½ in)
- Lockable storage frame for outrigger/stabiliser pads (additional weight: 4 kg/9 lbs)
- 4 outrigger/sliding pads (700 x 220 x 60 mm/2 ft 3 in x 9 in x 2½ in)
- Track mat (2000 x 800 x 15 mm/6 ft 6 in x 3 ft 3 in x ½ in)
- Safety harness
- 2 protective track covers, made of high-quality polypropylene fabric
- Tree package consisting of:
  - Protective cover hydraulic tank
  - Protective cover ground control panel
  - Covers on piston rod (outrigger/stabiliser) cylinders
- 4 covers on piston rod (outrigger/stabiliser) cylinders (additional weight: 10 kg/22 lbs)
- 2 headlights on engine unit

## TRAILERS

- Tandem Low Platform trailer (aluminium) including 4 tension belts (length 3,50 m/11 ft 6 in)  
Permissible total weight: 3500 kg/7,716 lbs  
Tandem rubber-sprung axle: 3500 kg/7,716 lbs  
Net weight: approx. 430 kg/948 lbs  
Wheels 155/70/R12 ET20  
Lighting fitting according to EU directives

**Enquiries from Europe, Asia, Middle East & Africa:**

**Corporate Headquarters**  
**Teupen Maschinenbau GmbH**  
Marie-Curie-Str. 13  
48599 Gronau, Germany  
phone +49 2562 8161-0  
fax +49 2562 8161-888  
mail@teupen.com  
www.teupen.com

**Enquiries from North & South America:**

**US Office**  
**Teupen USA, Inc.**  
10701 Southern Loop Blvd.  
Pineville, NC 28134, USA  
phone (704) 248-9871  
fax (704) 248-9889  
infousa@teupen.com  
www.teupen.com/us